

Suporte ajustável para LANÇA

Modelo DG 590/Z

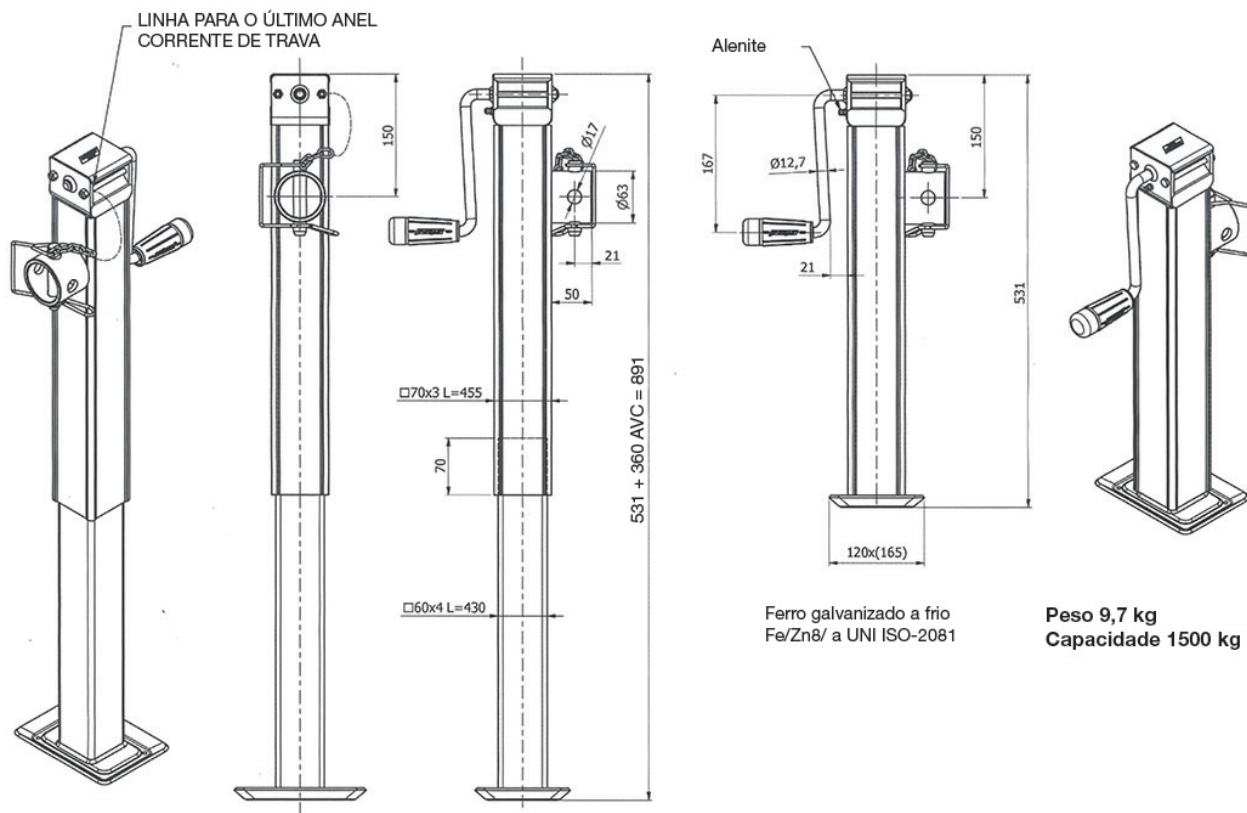

Modelo DT 496 HE/Z

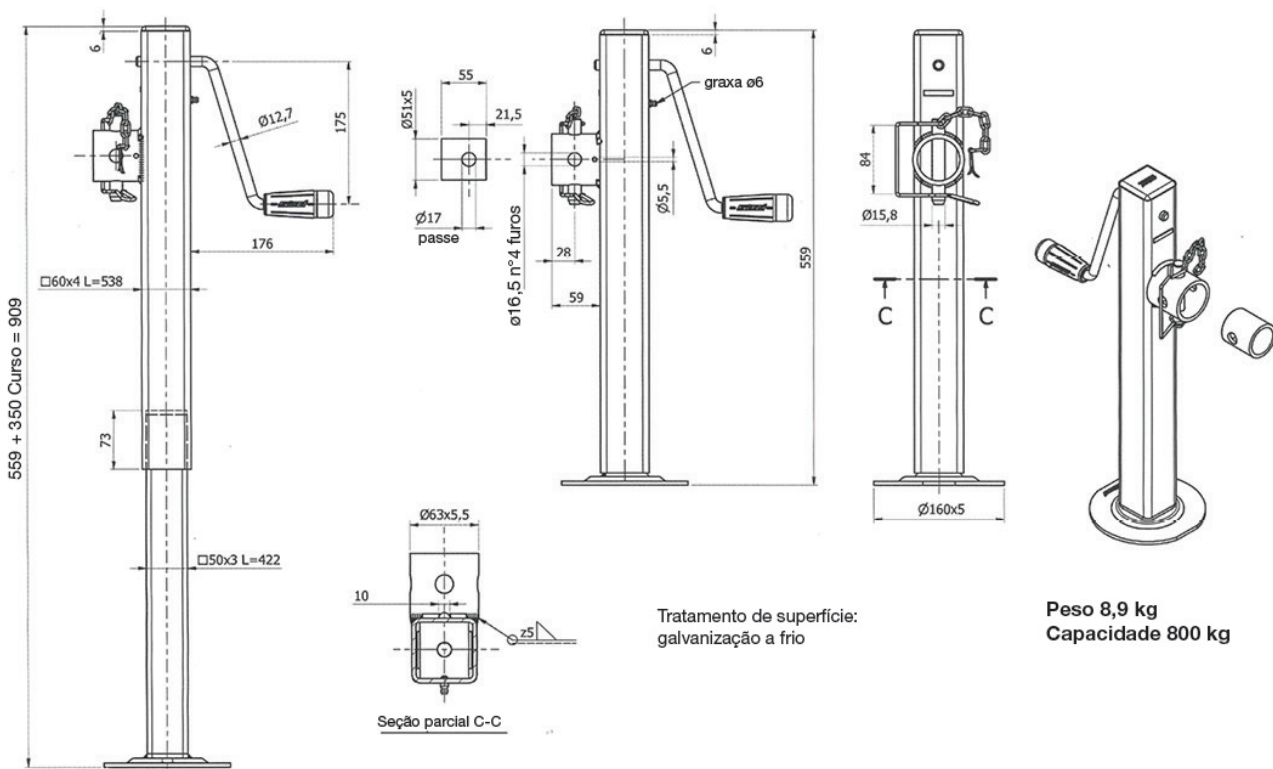

Modelo DV 320

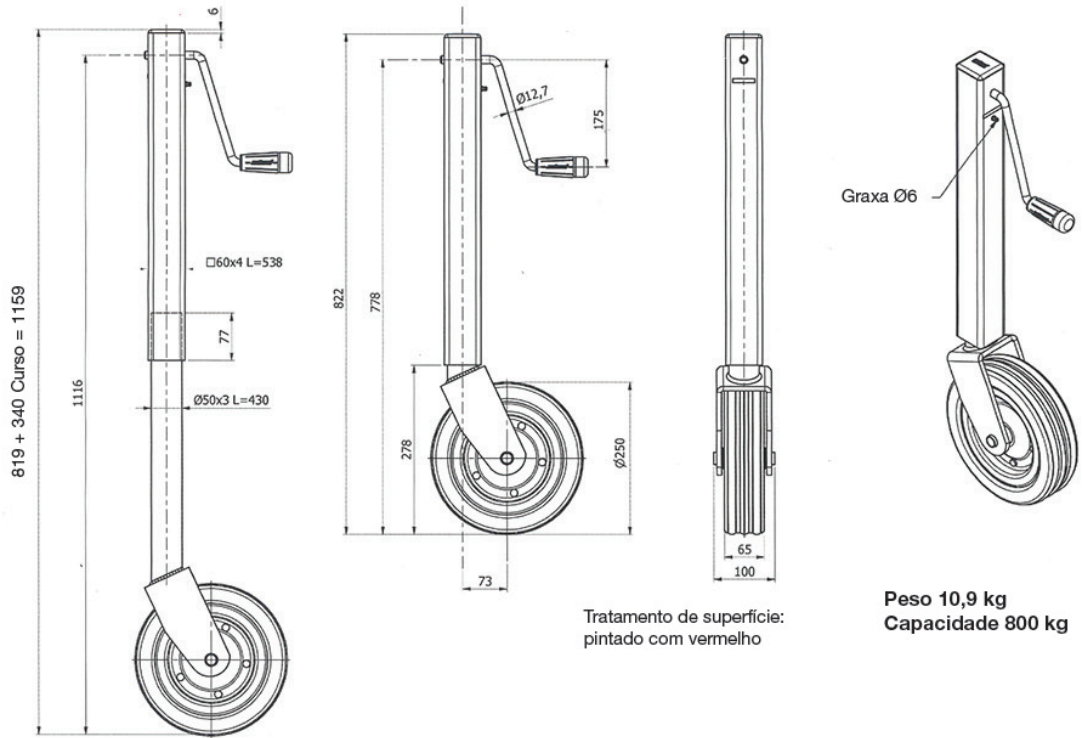

Formulários



Outros tipos, dimensões e capacidade disponíveis de acordo com a necessidade. Consulte o departamento técnico-comercial.